

Tous droits strictement réservés. Reproduction ou communication a des tiers interdite sous quelque forme que ce soit sans autorisation écrite du propriétaire. Propriété de c FCI. Droits de reproduction FCI.



All rights strictly reserved. Reproduction or issue to third parties in any form whatever is not permitted without written authority from the proprietor. Property of FCI. Copyright FCI.

PRODUCT NUMBER	PEG TYPE	TAIL TYPE	TAIL LGTH. DIM "A"	PCB THICKNESS	LOADING CONFIGURATION
89093-X02	PRESS	PRESS-FIT	2.90	1.6	FULLY LOADED
89093-X12	PRESS	PRESS-FIT	3.53	2.4	FULLY LOADED
89093-X02LF	PRESS	PRESS-FIT	2.90	1.6	FULLY LOADED
89093-X12LF	PRESS	PRESS-FIT	3.53	2.4	FULLY LOADED

PLATING CONTACT AREA:	
DASH NR:	PERFORMANCE LEVEL
-1YY	TELCORDIA CO
-2YY	CUSTOMER SPECIAL
-3YY	CUSTOMER SPECIAL
-9YY	TELCORDIA CO
-1YYLF	TELCORDIA CO
-2YYLF	CUSTOMER SPECIAL
-3YYLF	CUSTOMER SPECIAL
-9YYLF	TELCORDIA CO

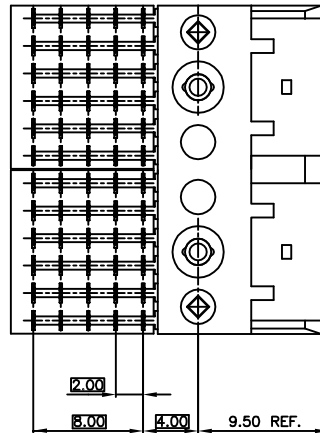
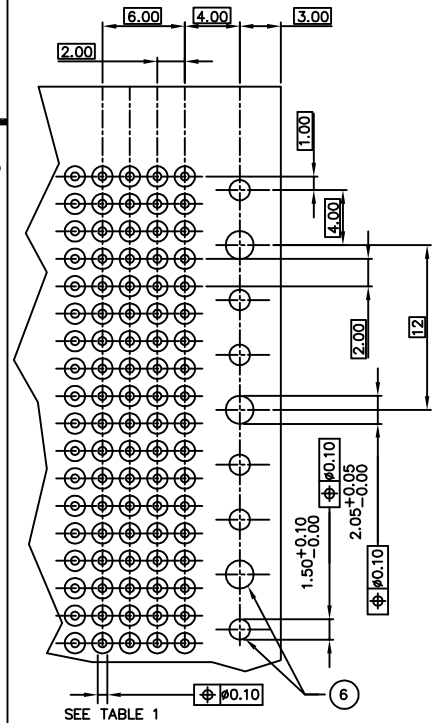
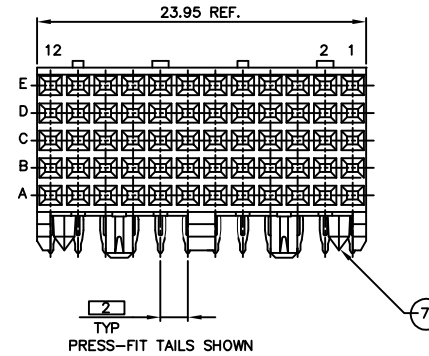
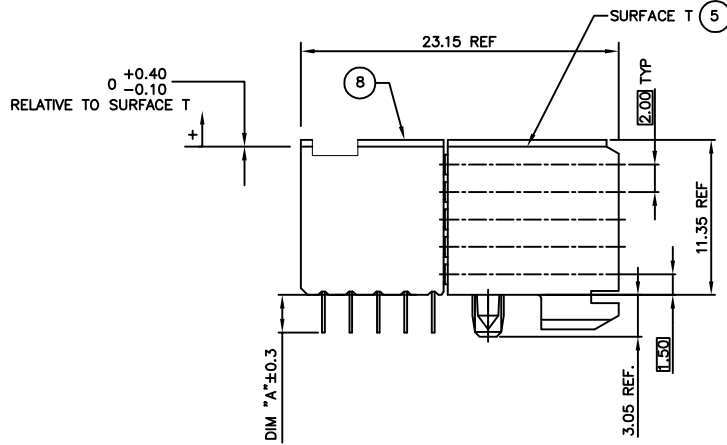

HOLE DIAMETER AFTER PLATING	0.65-0.80
DRILLED HOLE	0.81-0.86 (0.85 DRILL)
COPPER PLATING	0.025 - 0.05
SnPb PLATING	0.005-0.015

RECOMMENDED PC BOARD LAYOUT, COMPONENT SIDE.

NOTES:

- CONNECTOR MATERIALS:
HOUSING: LCP, 30% GLASS FILLED, UL 94-V0 COMPLIANT
TERMINAL: PHOSPHOR BRONZE ALLOY
- TAIL PLATING:
PRESS-FIT TYPE: 0.5-1.5 um TIN LEAD
- PRODUCT SPECIFICATION:
GS-12-002
- APPLICATION SPECIFICATIONS:
BUS-20-061
GS-20-001
TA-941
- PRODUCT MARKING: (PART NUMBER & LOT CODE).
- INDICATED HOLES ARE UNPLATED.
- DIAMOND LOCATION PEG ARE ONLY EXISTED ON THE BOTH SIDES OF PRODUCT.
- TOP SURFACE OF PRESS BLOCK MAY EXTEND UP TO 0.4MM HIGHER THAN HOUSING. THIS MAY AFFECT THE TAIL LENGTH BEFORE APPLICATION TO A BOARD.
- THESE PRODUCTS WHERE THE PART NUMBER ENDS IN "LF" MEET THE EUROPEAN UNION DIRECTIVES AND OTHER COUNTRY REGULATIONS AS DESCRIBED IN GS-22-008.
ALL PRODUCTS WILL WITHSTAND EXPOSURE TO 240°C FOR 60 SECONDS IN A CONVECTION, INFRARED OR VAPOR PHASE REFLOW OVEN.
- FOR LEAD FREE PART NUMBERS ADD "LF" SUFFIX. EXAMPLE: 89093-XYLLF.

mat'l. code		tolerances unless otherwise specified		CUSTOMER COPY		FCI	
NOTE 1				projection		www.fciconnect.com	
ltr	ecn no	dr	date	linear	MM	title	
N	0G06-0510	Cenh	12/06/06			B SERIES R/A SIGNAL RECEPT ASSY,	
P	0G07-0168	Cenh	05/10/07			5 ROW, 2 MOD, PF	
R	0G08-0171	TER	8/26/08	angles		product family	METRAL
				dr	C. DAILY	06/18/02	code
K	V03-0722	LP	8/22/03	enrg	M. GRAY	06/18/02	213
L	V05-0074	LP	4/12/05	chr	M. GRAY	06/18/02	size
M	J05-0320	TAB	6/08/05	appd	M. GRAY	06/18/02	dwg no
							89093
sheet	revision	R					code
index	sheet	1					22526